

FPDJ

...

Baltazar Ortiz, Angus MacMullen, Elena Byun

Overview

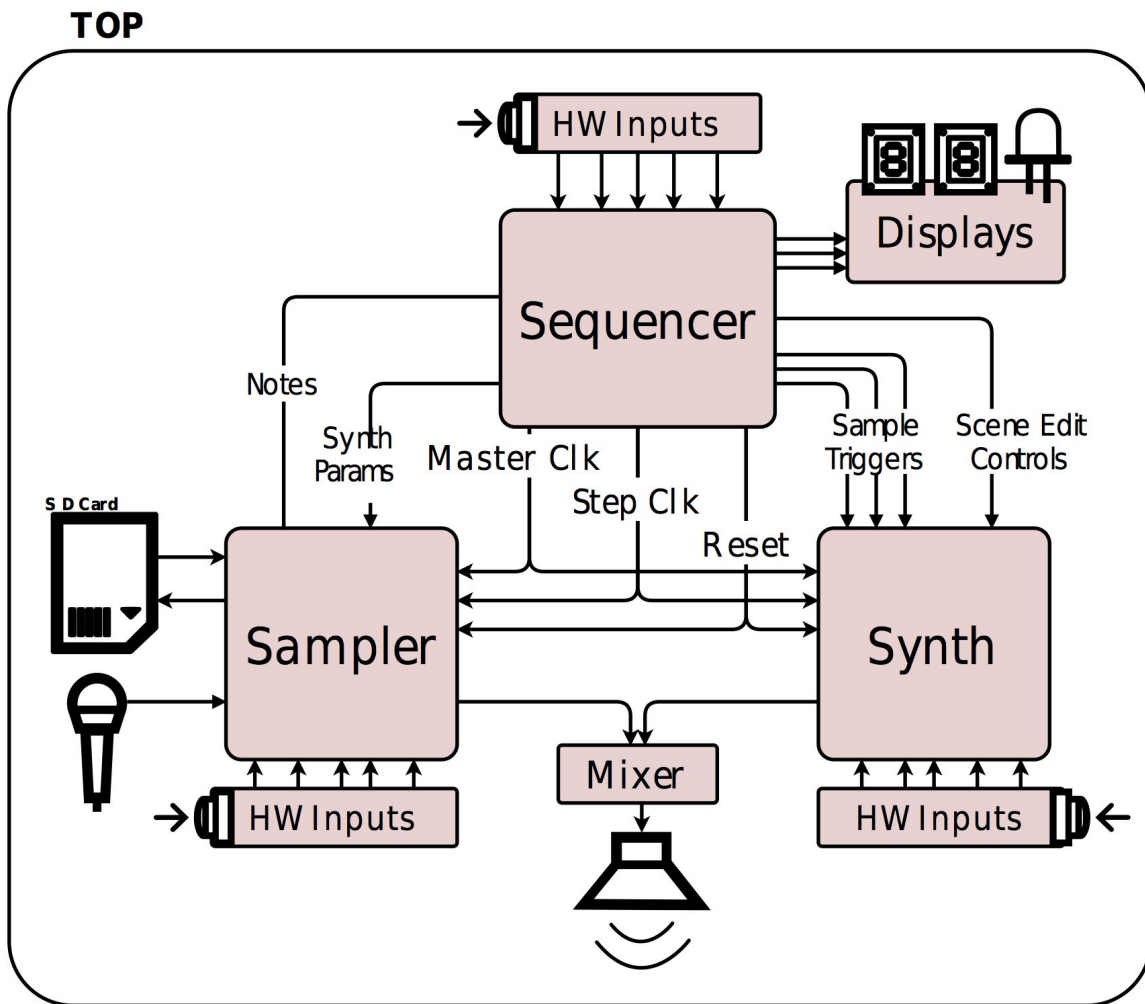

Sampler

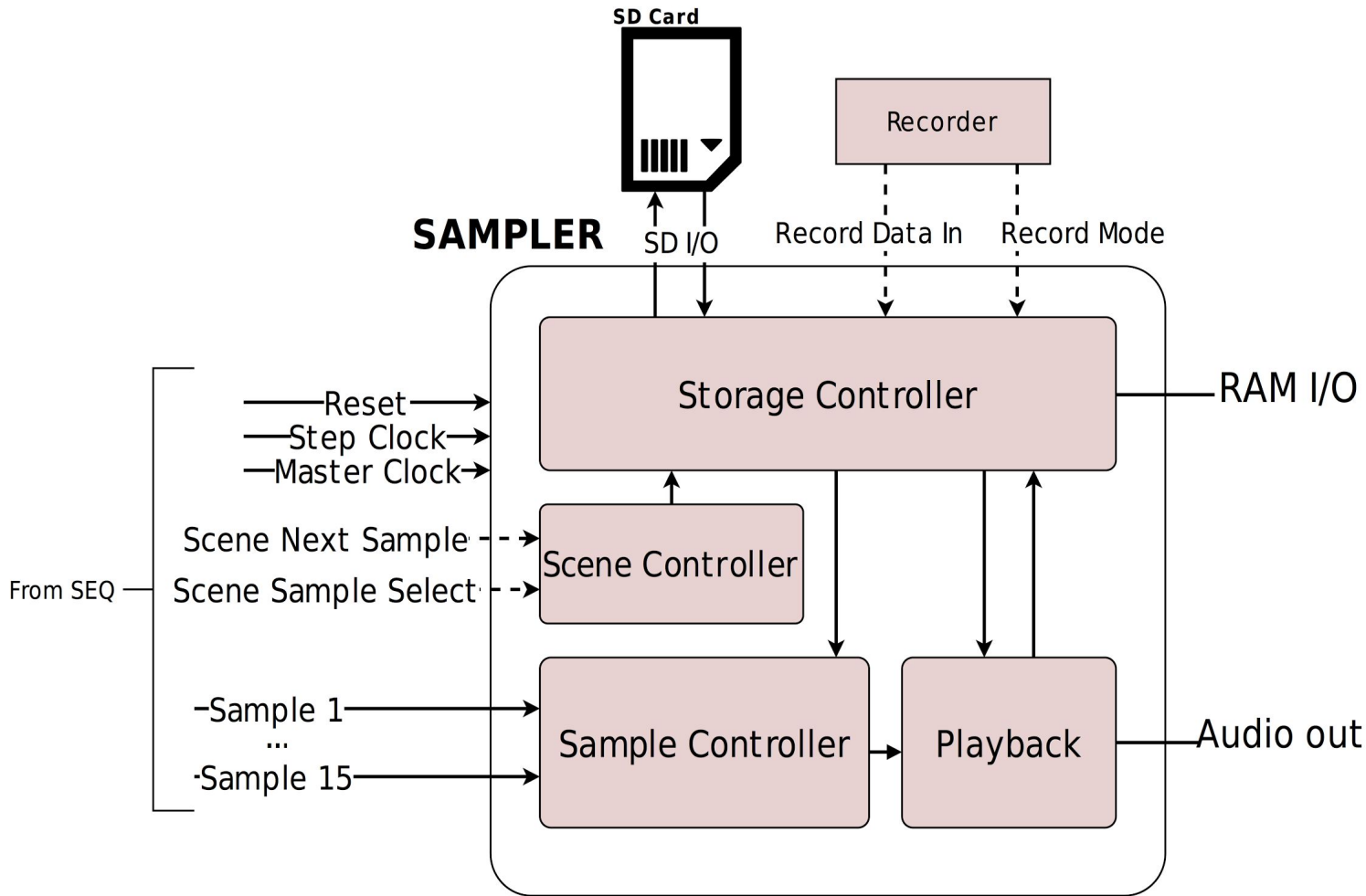

Synthesizer

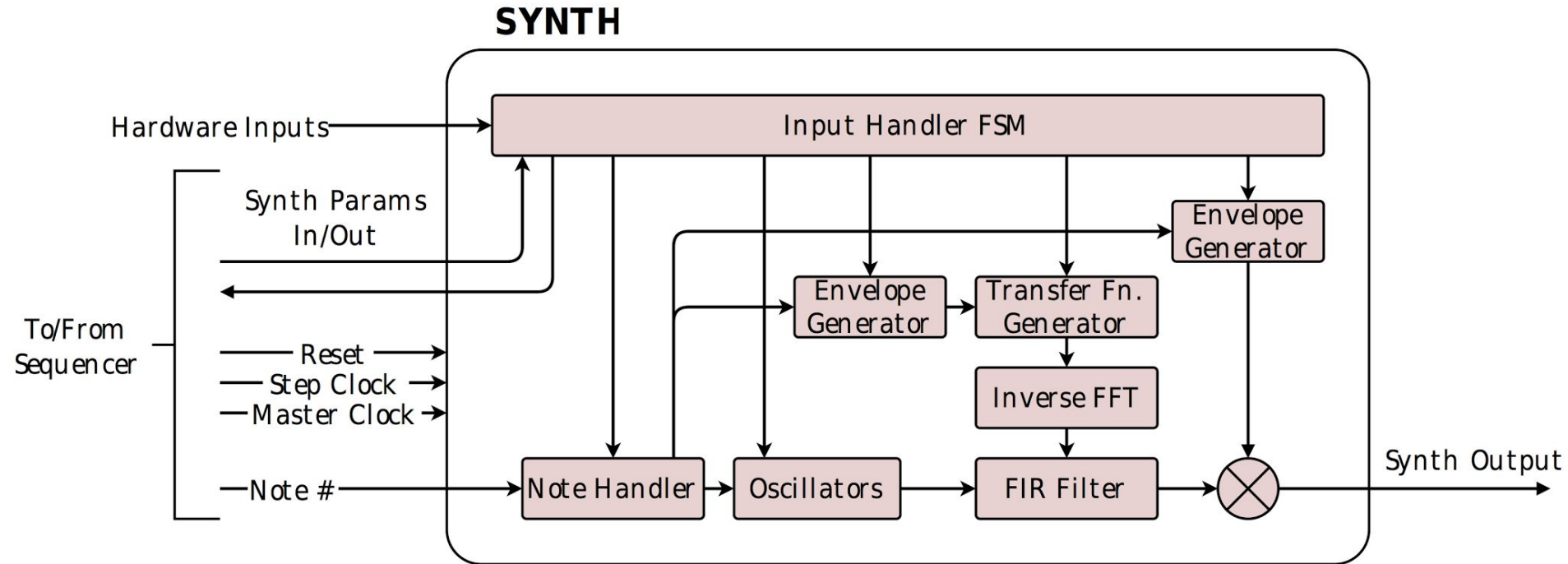

SEQ

Sequencer

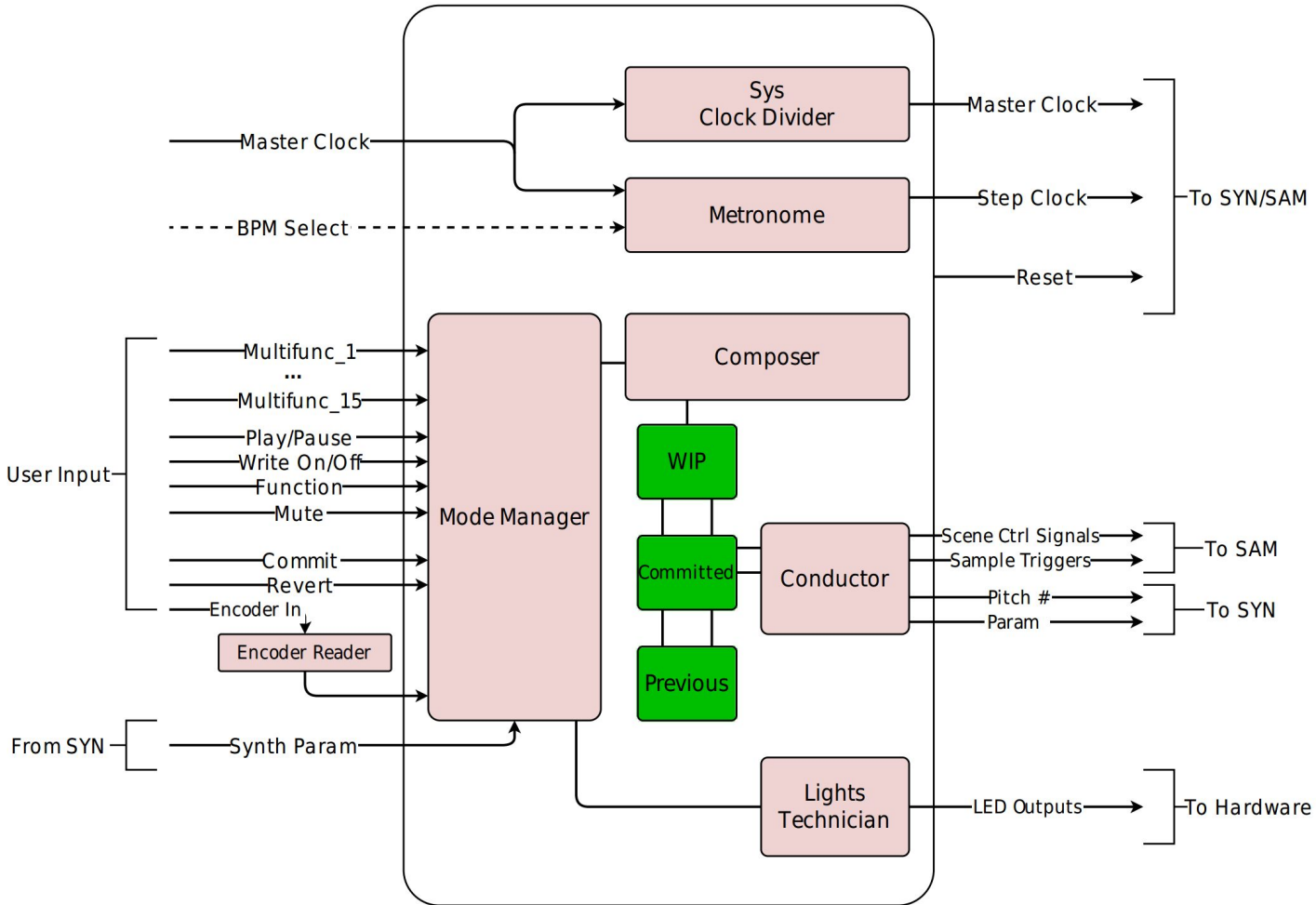

Resources

Nexys DDR board

- Sampler
 - Need as much RAM as possible
- Synth
 - FFT - significant area
 - lots of multiplies
- Sequencer
 - lots of i/o

Hardware

- Tactile Switches
- Pots
- Encoders
- RGB LEDs
- Mux / Shift registers
- DAC (optional)

Timeline

	Sampler	Synthesizer	Sequencer
11/7-11/13	Storage Controller	Oscillators Note handler Begin input handler	Composer Memory Management Begin Mode Manager
11/14-11/20	Playback	FIR filter Simple transfer fns. Input handler	Mode Manager FSM Input Handling Conductor
11/21-11/27	Sample Controller	Advanced transfer fns. Envelopes	Hardware I/O
11/28-12/4	Scene Controller		
12/5-12/11	Reach goals and integration		