



Pianos are large, heavy, and expensive



Virtual Piano is easy to transport



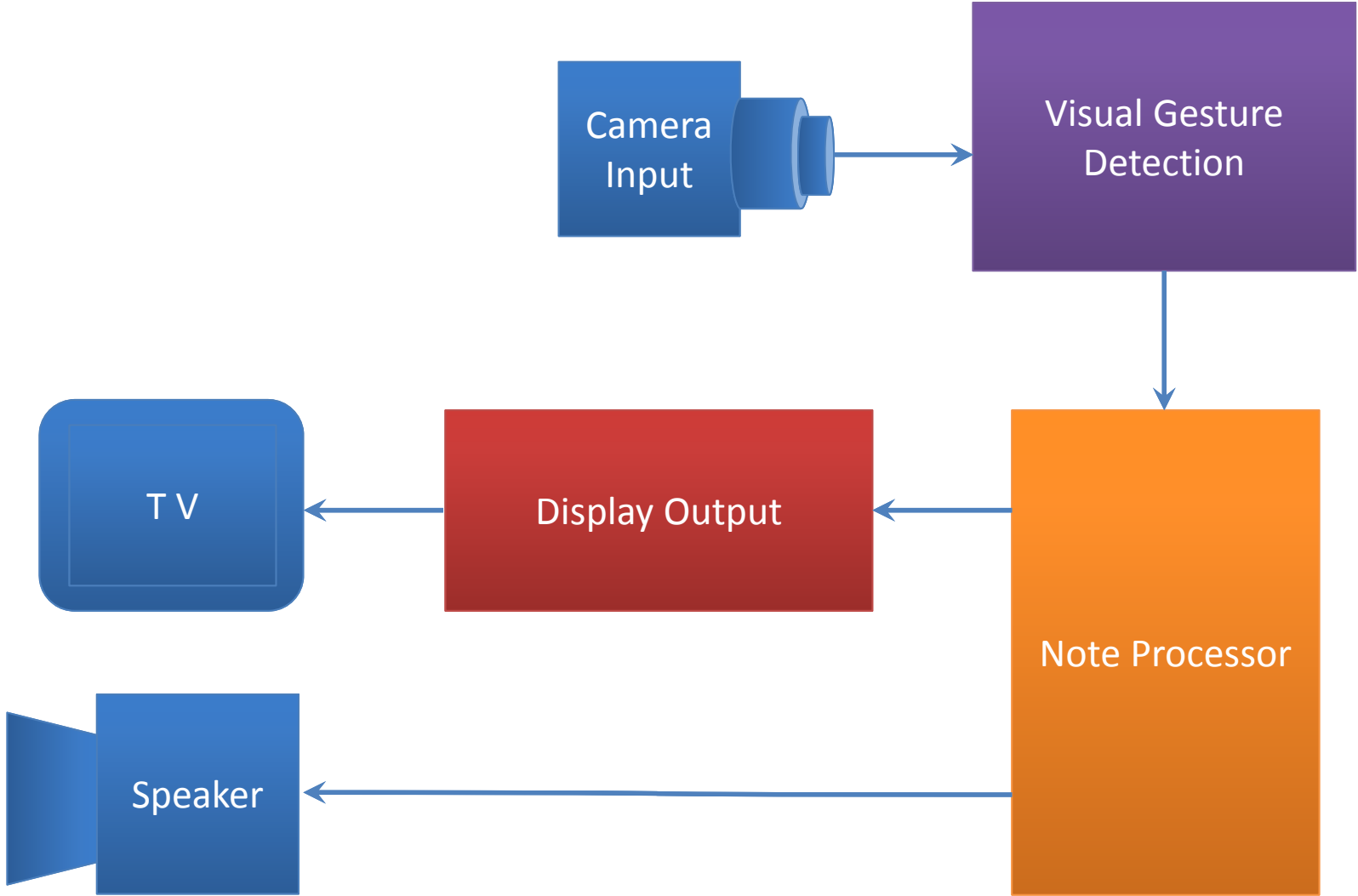

Visual Gesture Detection

Processes images from camera and sends note name and attack to note processor

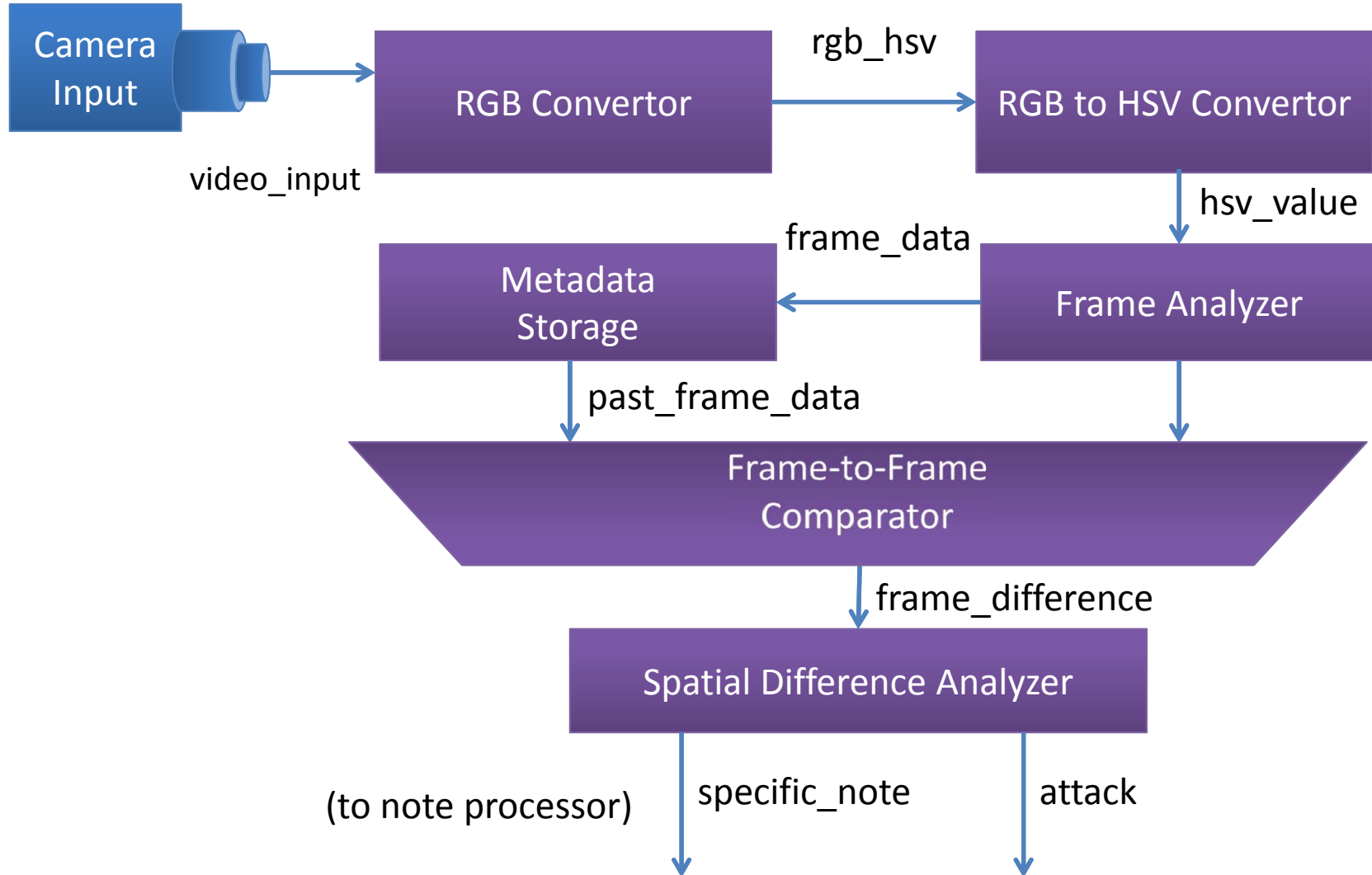

Writing Music to Bar Staff

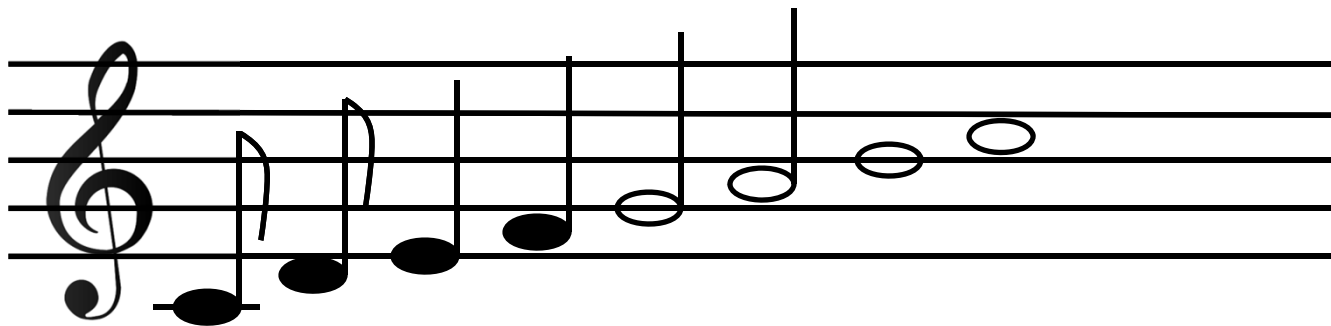
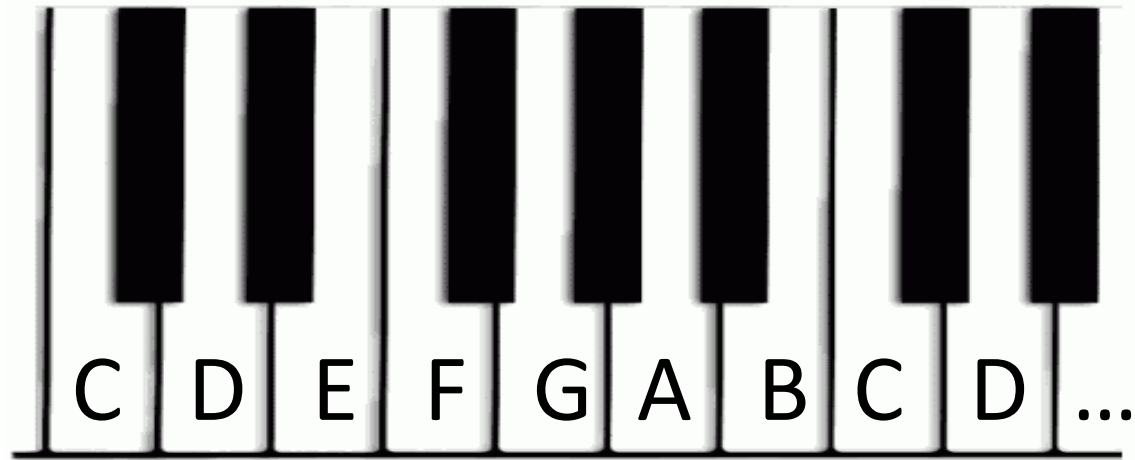

Note Processor

receives data from gesture detection module, outputs to display and audio

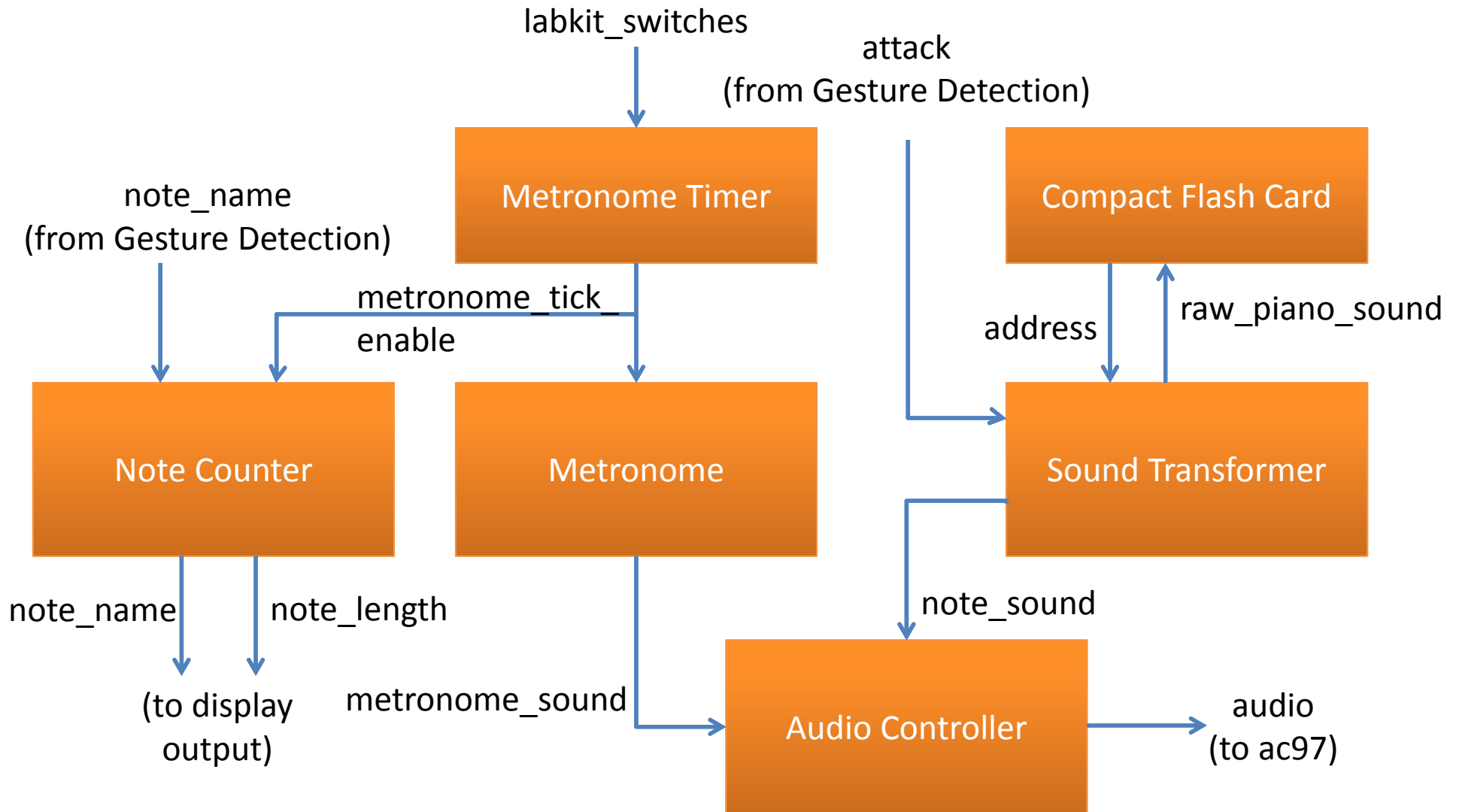

Display Output

Receives note length and note name and displays them on screen

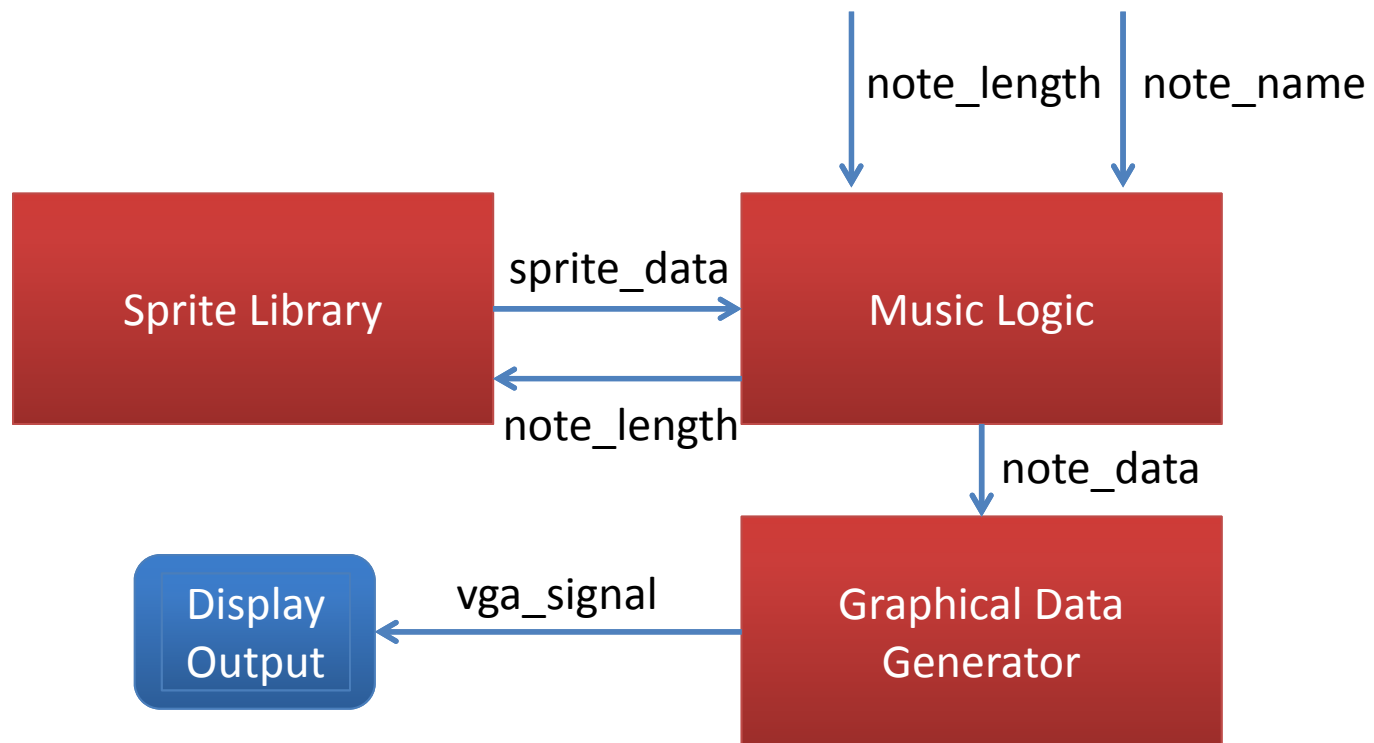

Schedule

- Week of 11/11
 - Work on gesture detection – be able to detect 2 fingers
 - Be able to store and play audio
- Week of 11/18
 - Debug display module
 - Work on note processing
- Week of 11/25
 - Debugging, combining modules, implementing stretch goals
- Week of 12/2
 - Debugging!

?

s