

# Decision-Feedback Equalizer

Zhipeng Li  
Yan Huang

# Overview

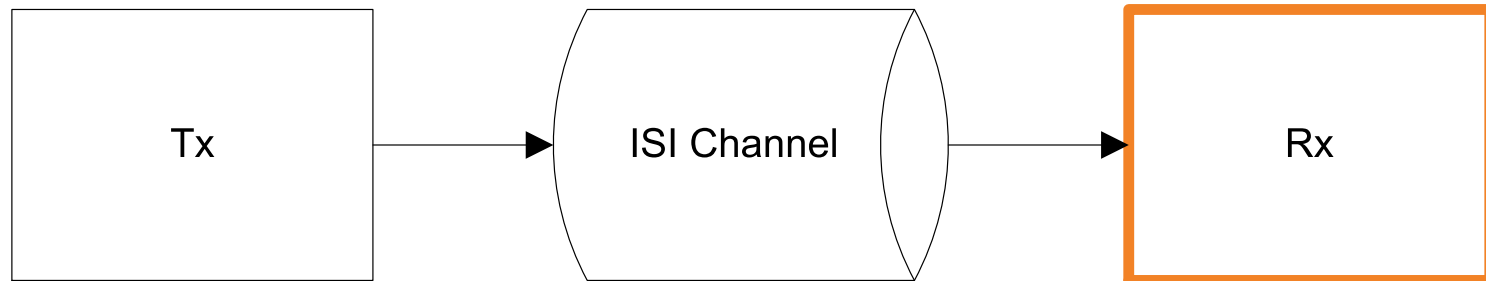

# InterSymbol Interference (ISI)

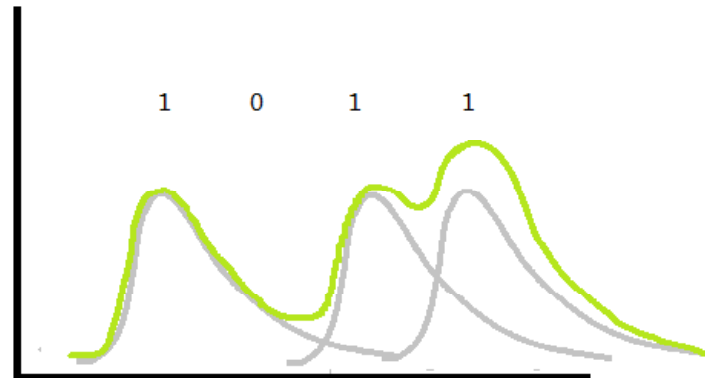
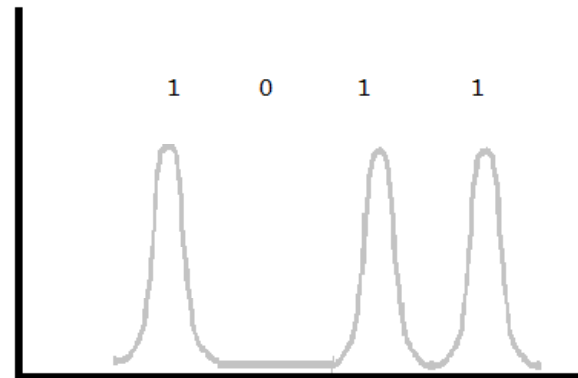
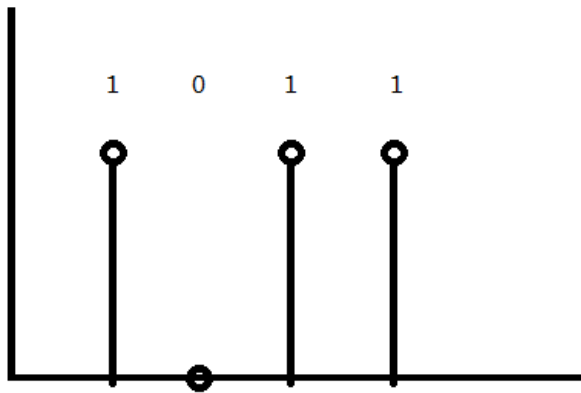

# Decision Feedback Equalizer (DFE)

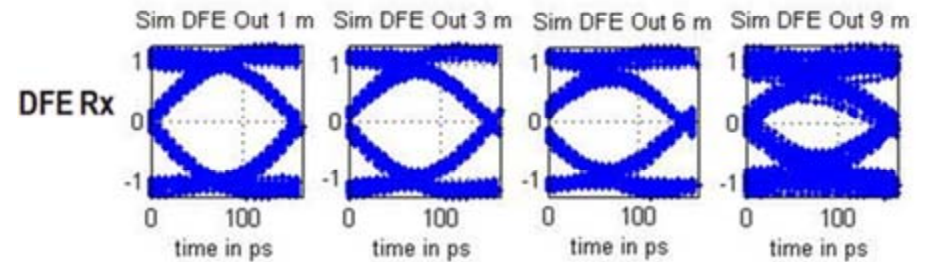
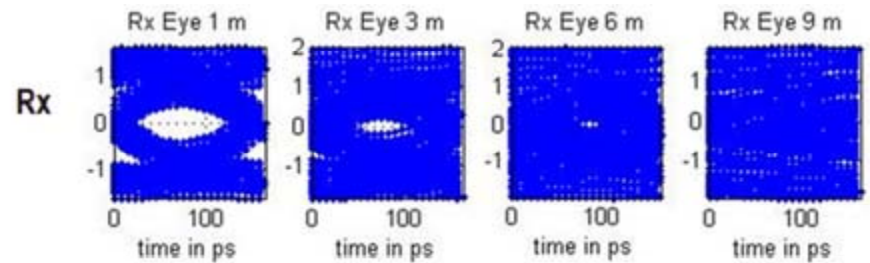
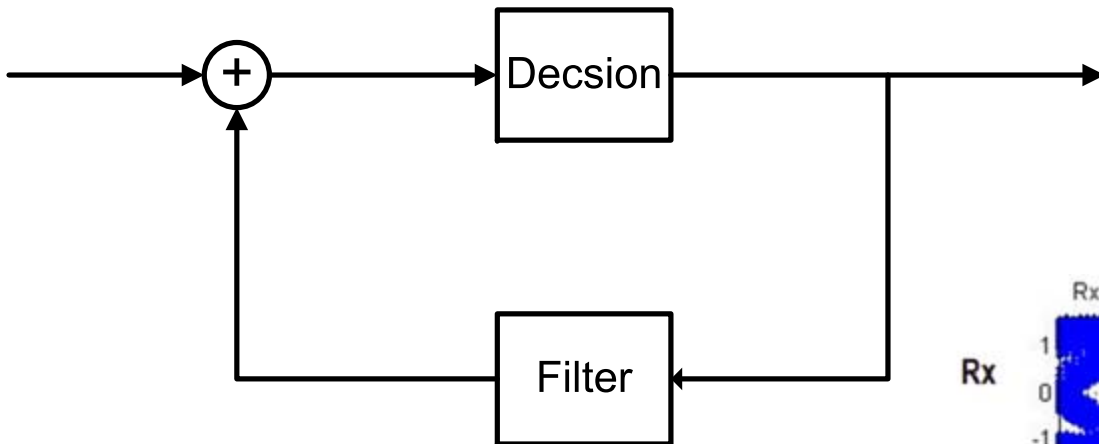

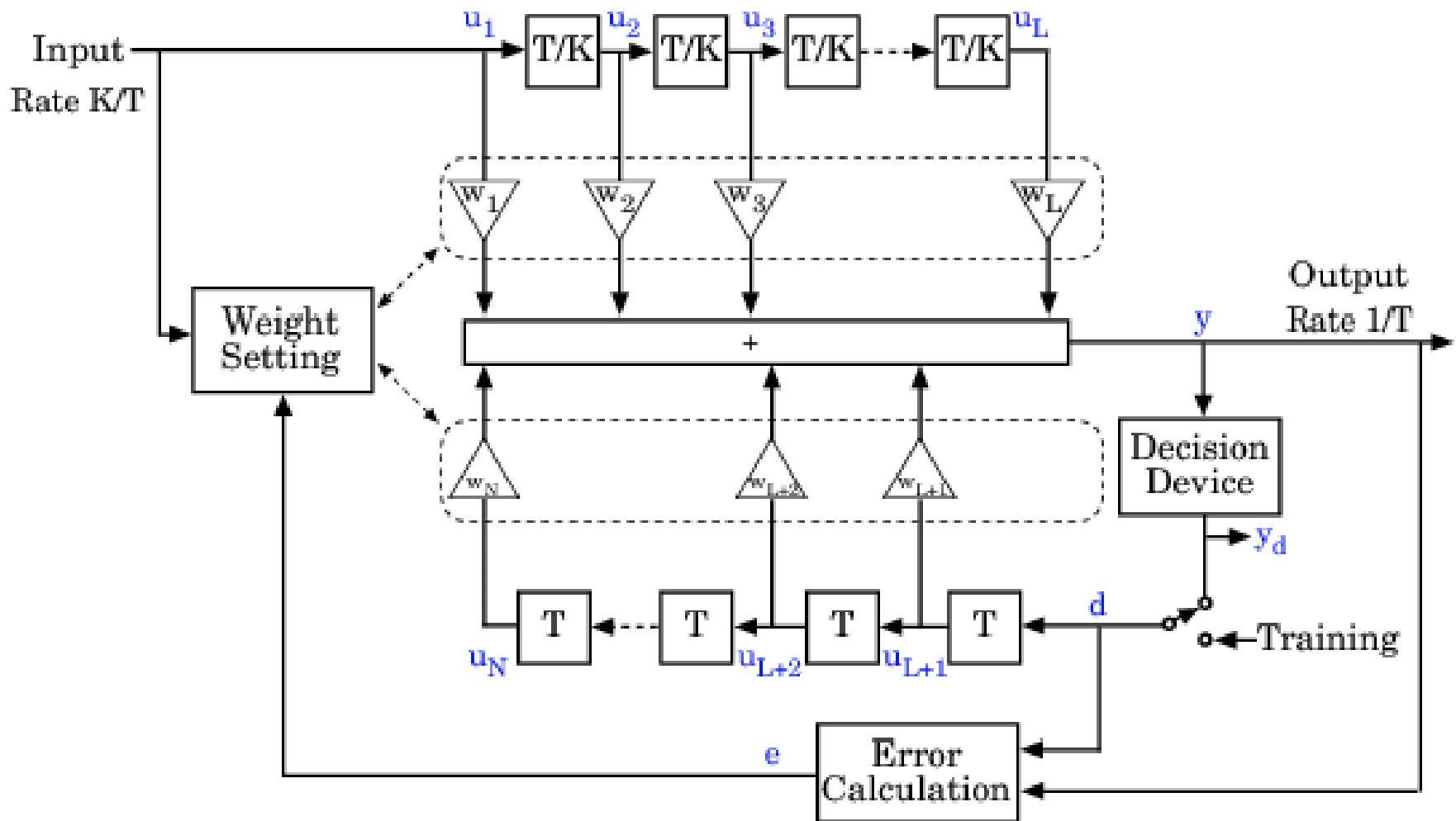

$H_1$ , if  $F(r|H_0)P(H_0) < F(r|H_1)P(H_1)$

$H_0$ , if  $F(r|H_0)P(H_0) > F(r|H_1)P(H_1)$

If  $P(H_0) = P(H_1)$

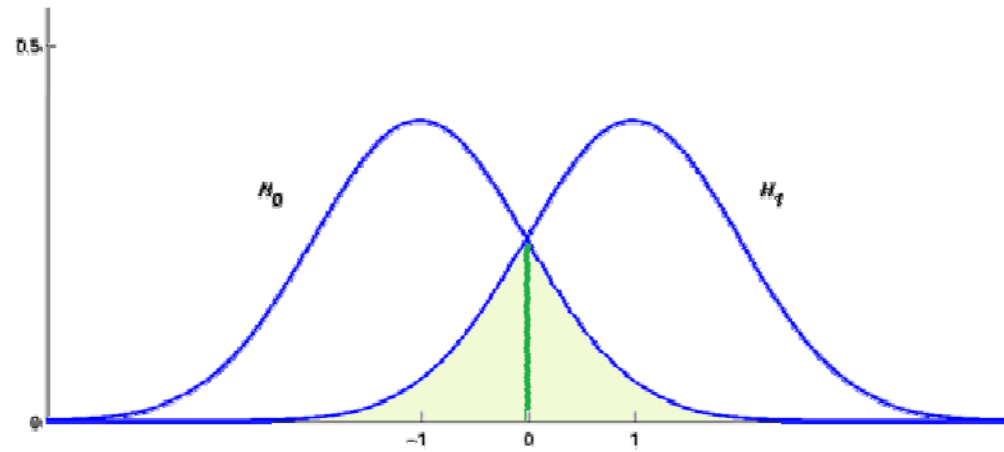

If  $P(H_0) \neq P(H_1)$

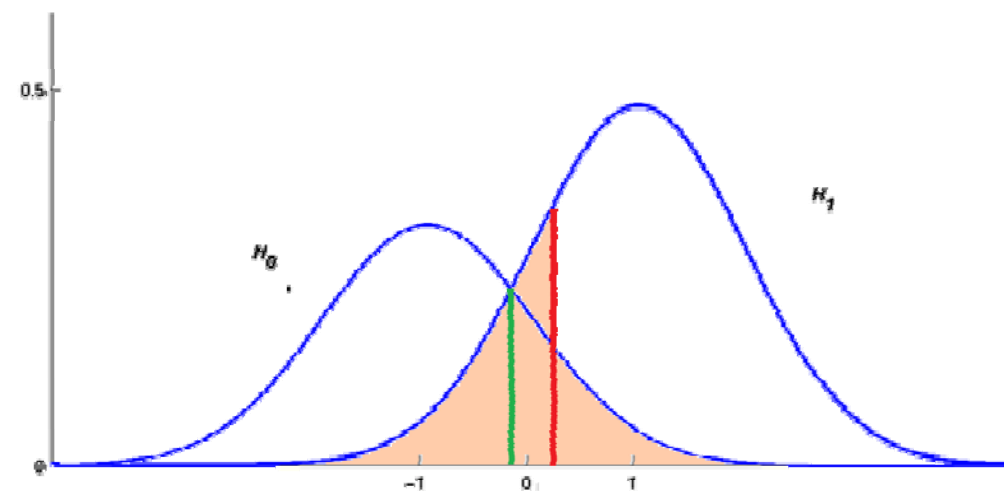

# Block Diagram

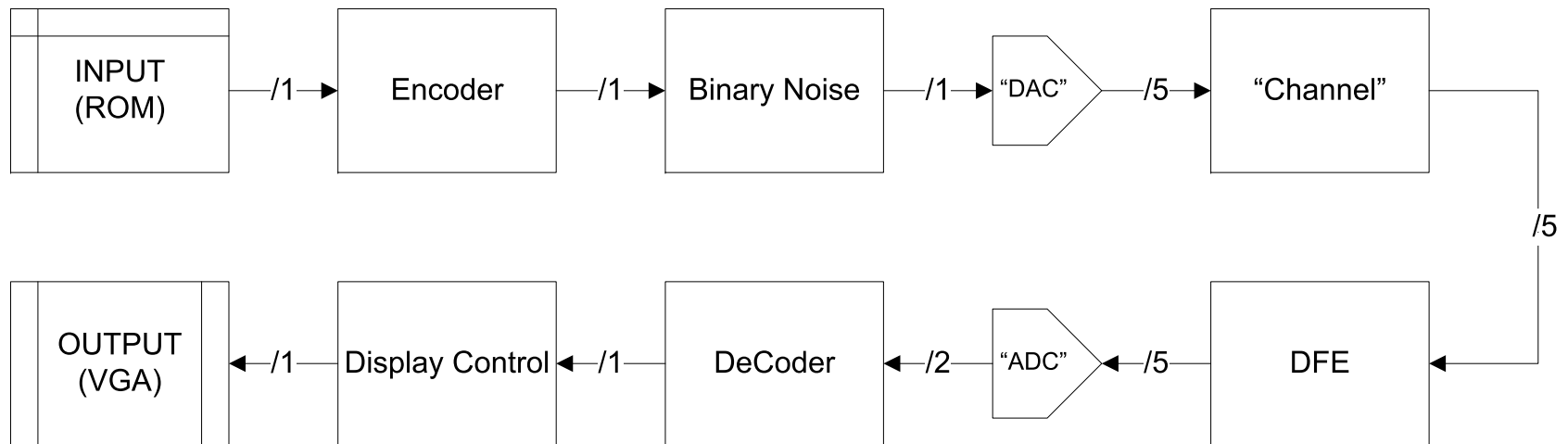

# TimeLine

