

# **Crash Avoidance System**

By Kristen Anderson  
and Kat Kononov

# Motivation



[http://wallpaperstock.net/car-crash\\_wallpapers\\_5294\\_1280x1024\\_1.html](http://wallpaperstock.net/car-crash_wallpapers_5294_1280x1024_1.html)

# Objective

- Crash avoidance system
  - Static and dynamic avoidance
- Implemented on RC car



# Overview

- Components
  - Labkit
  - RC Car and remote
  - Distance sensors
  - XBee radios
  - IR remote and receiver

# Overview

## High-level Block Diagram

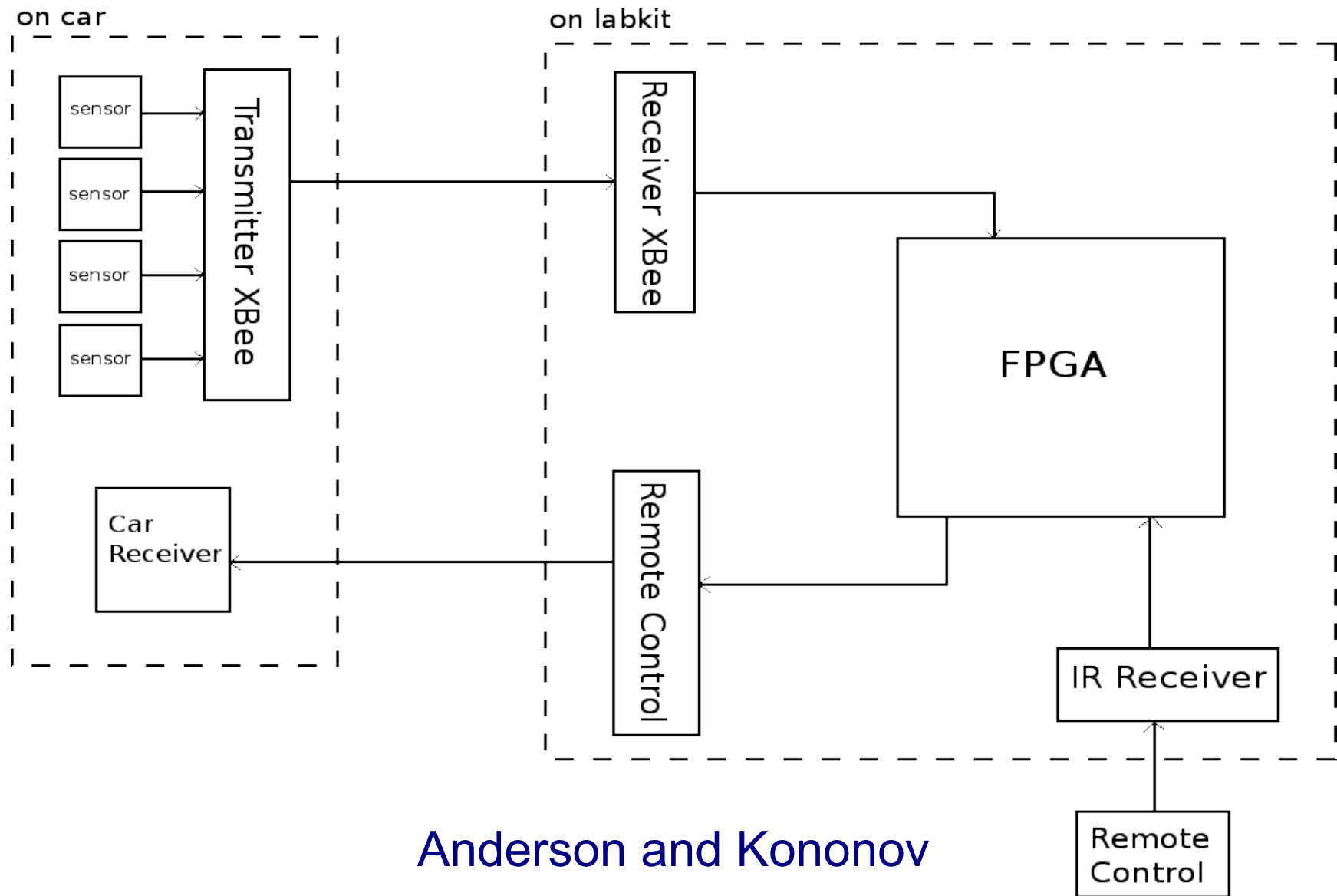

# Main Modules

## FPGA Block Diagram

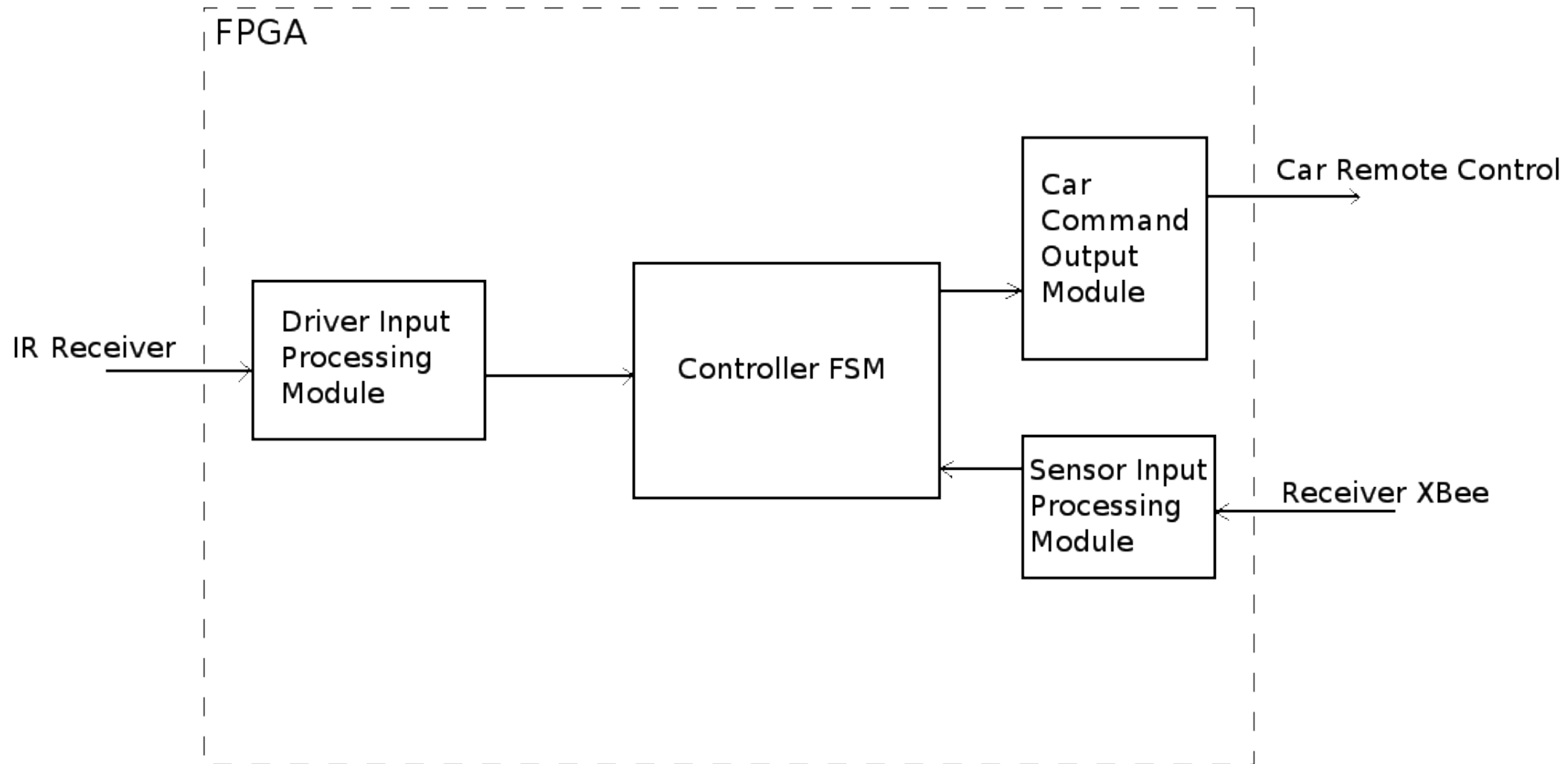

# Driver Input Module

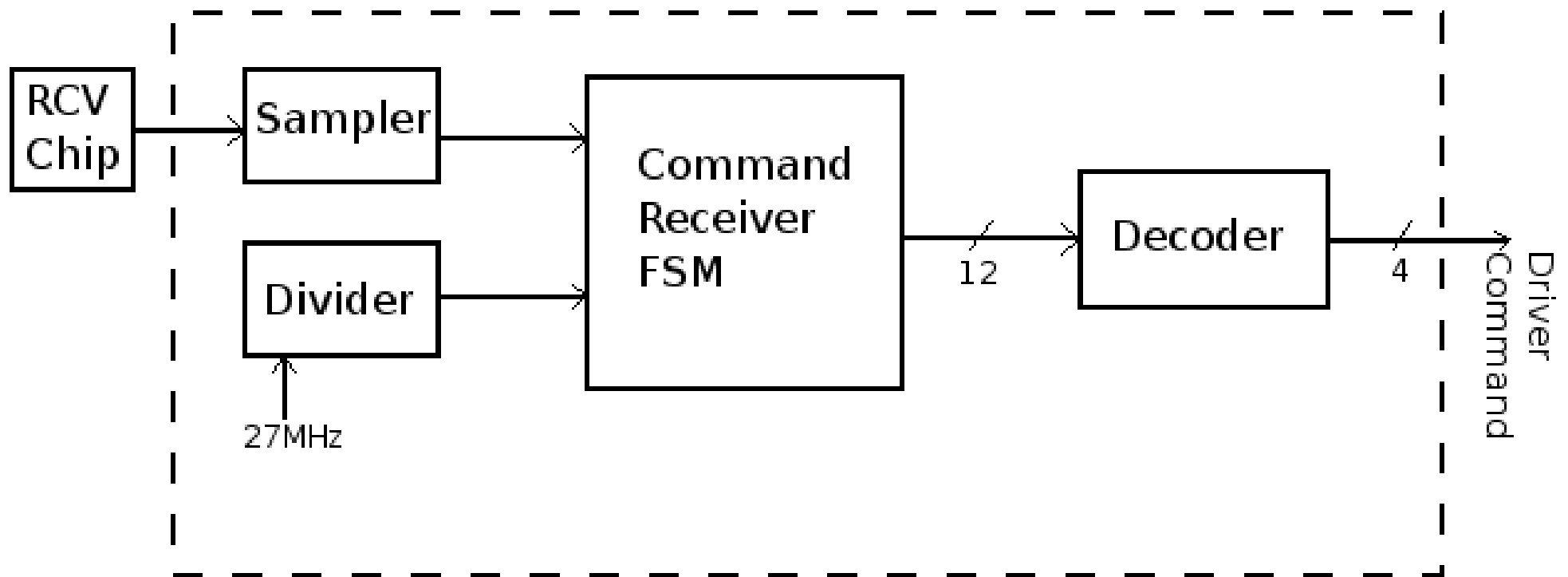

# Sensor Input Module

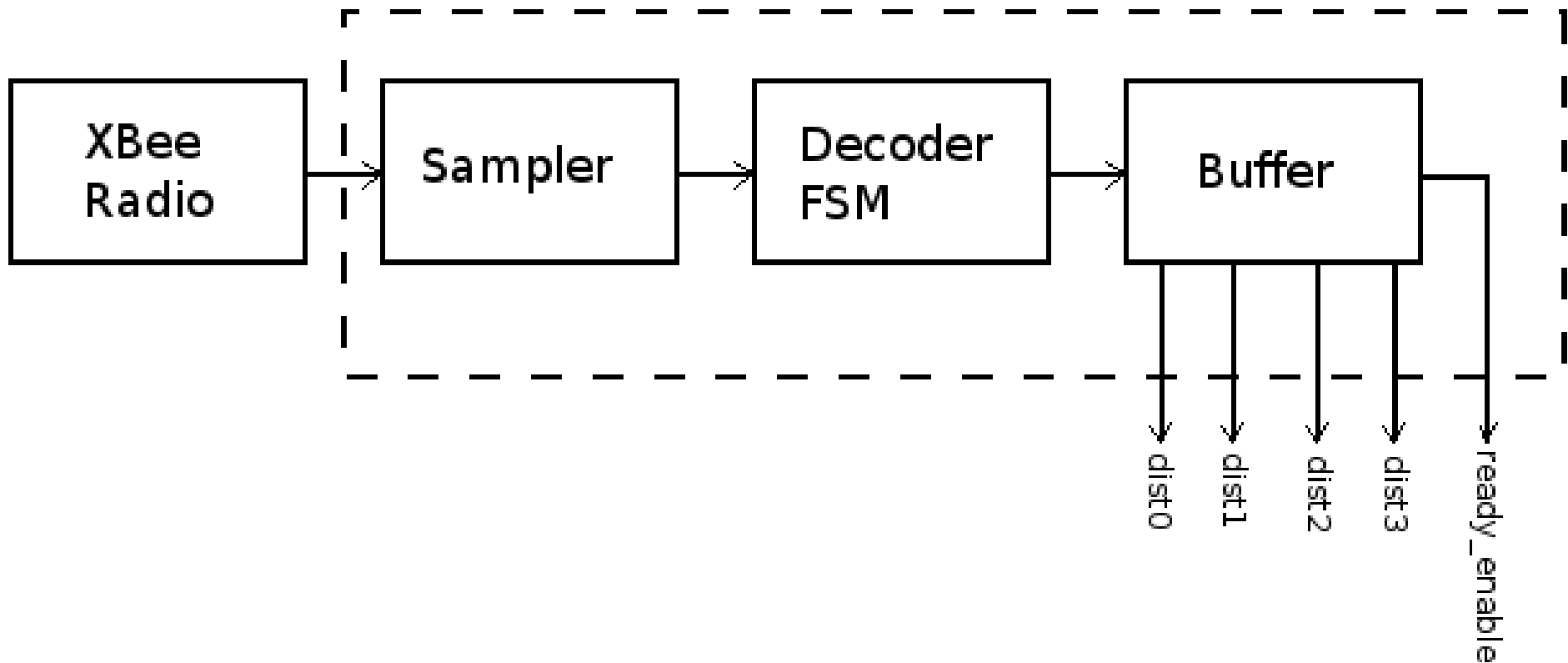



# Command Output Module

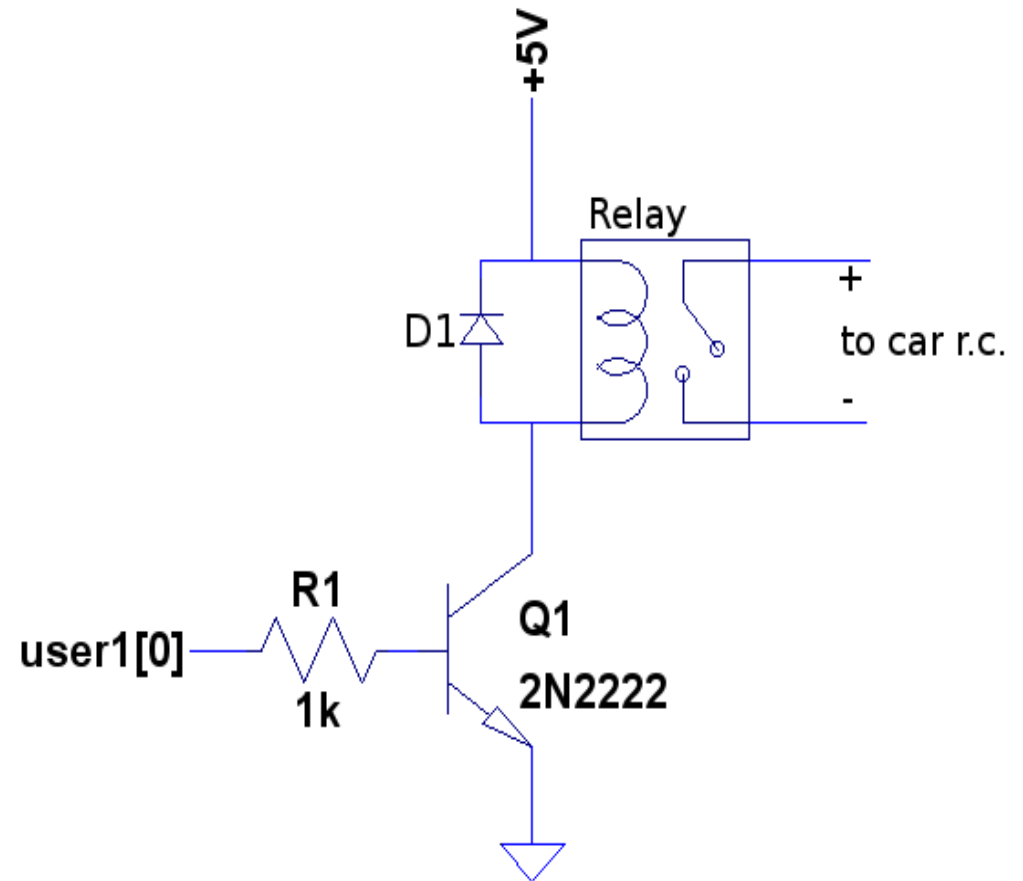
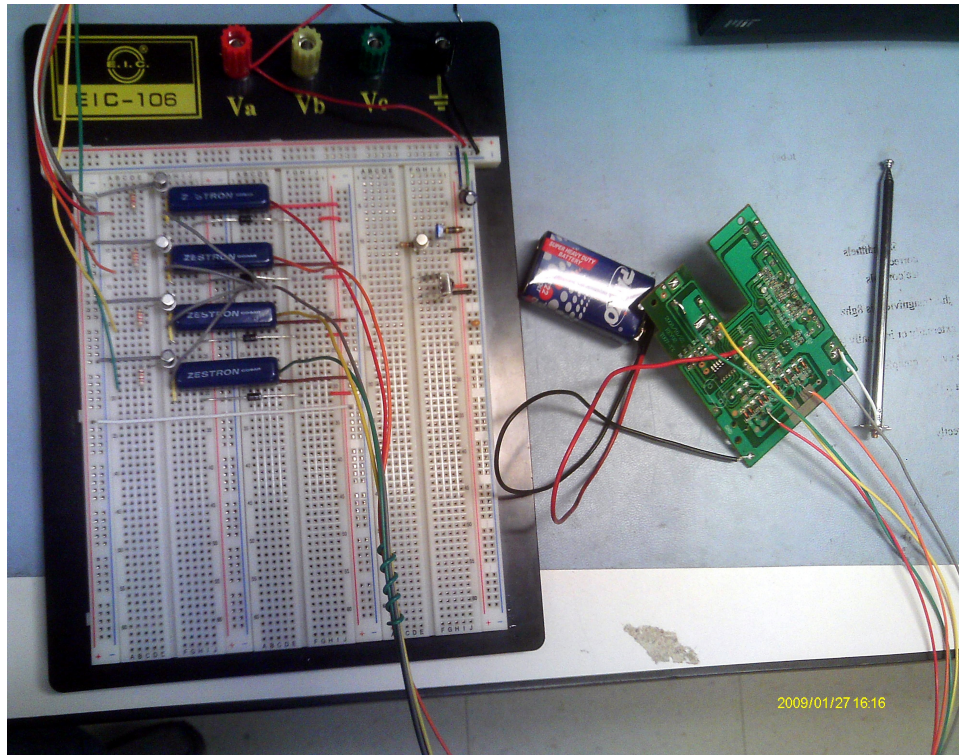

# Extension

- Mapping surroundings
- Based on sensor data

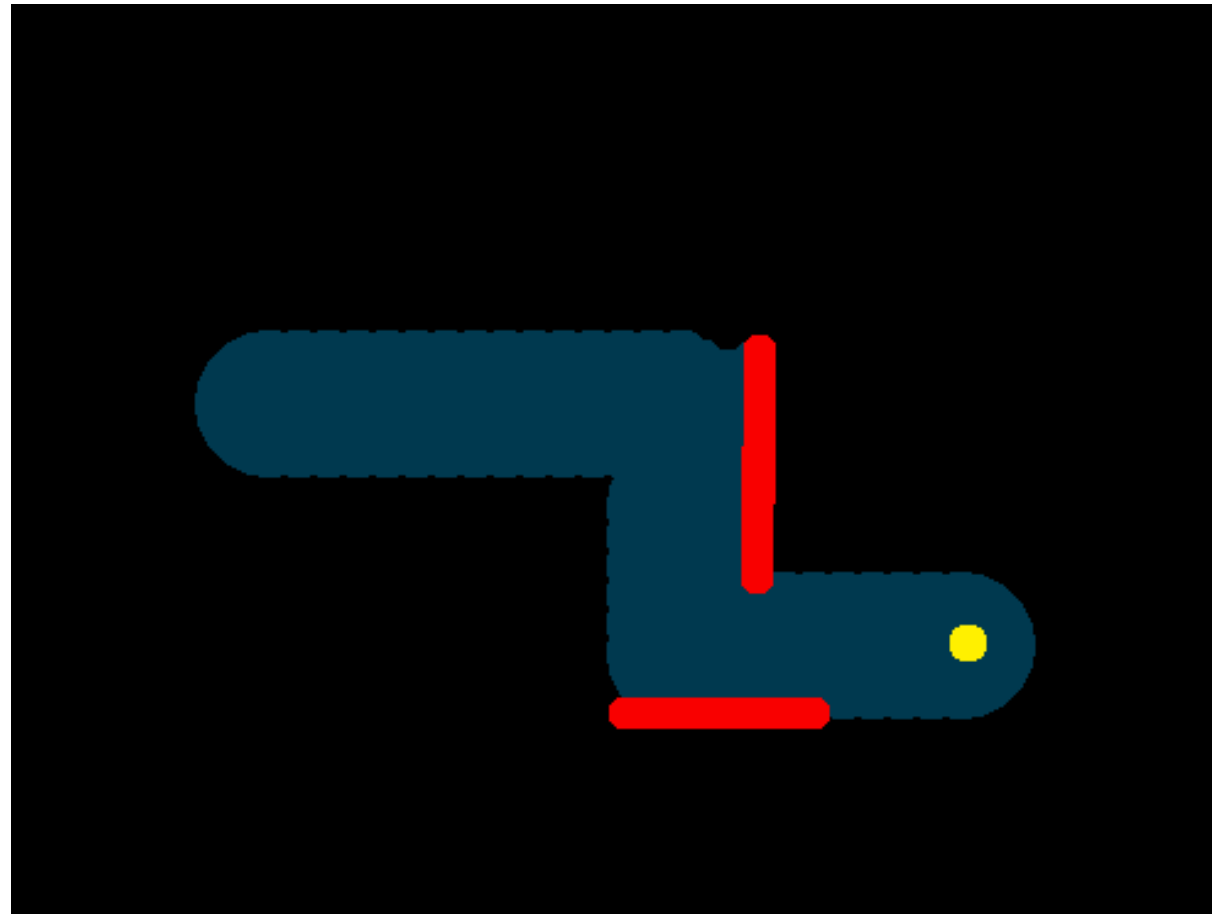

# Controller FSM

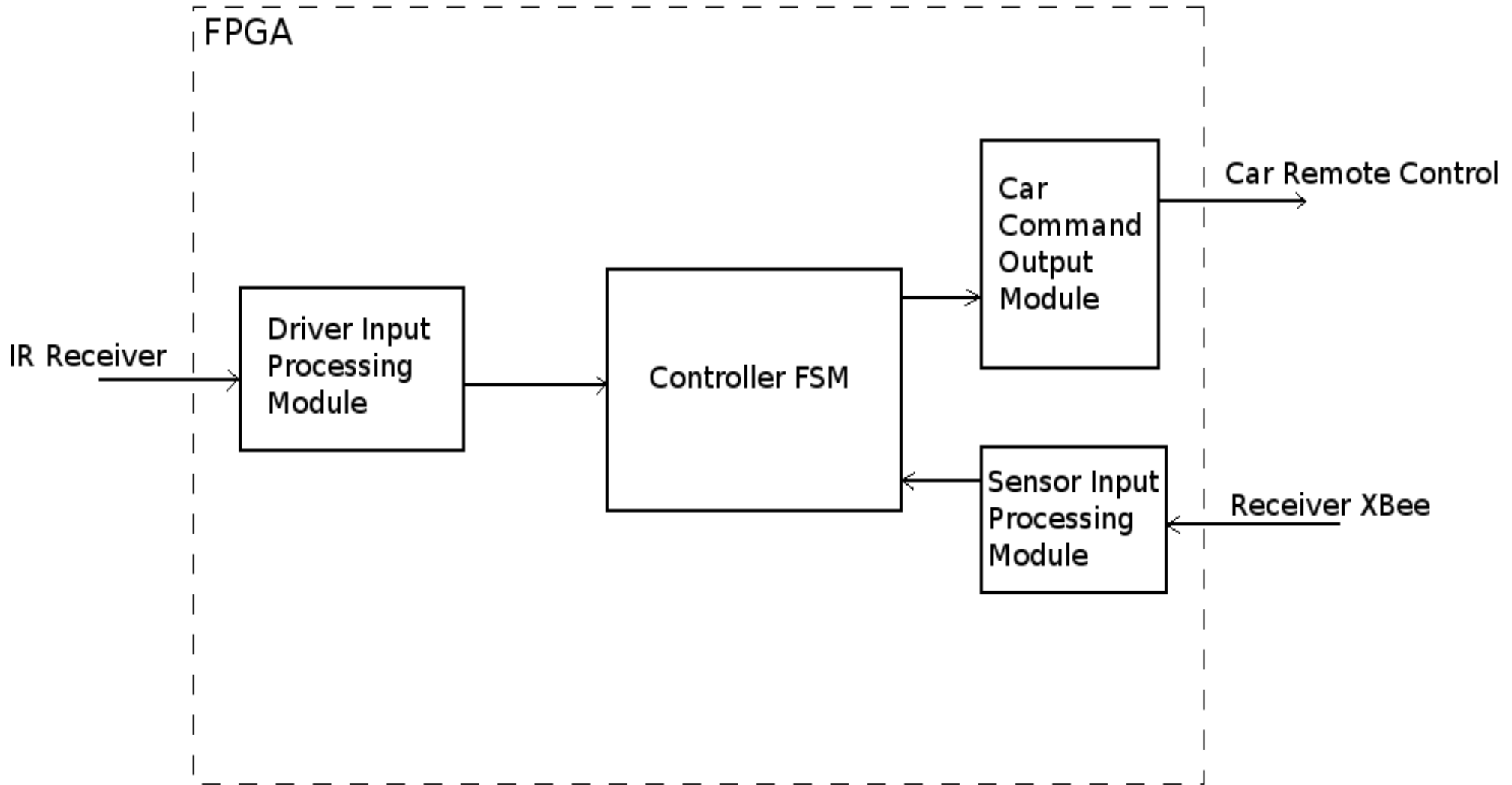

# Side Object Avoidance

No Right Turn

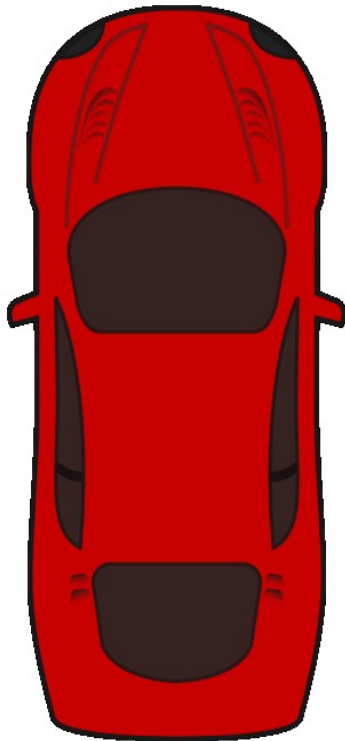

No Left Turn

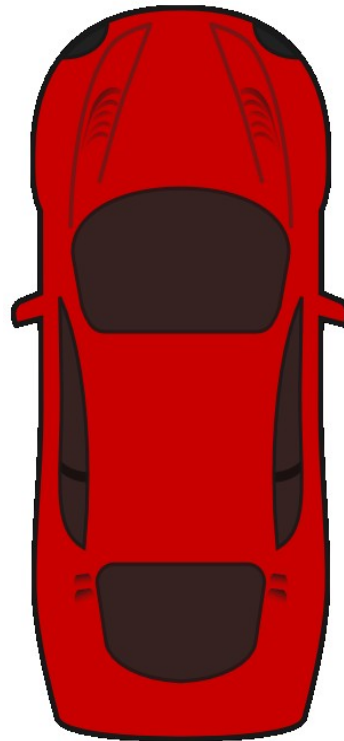

No Turn

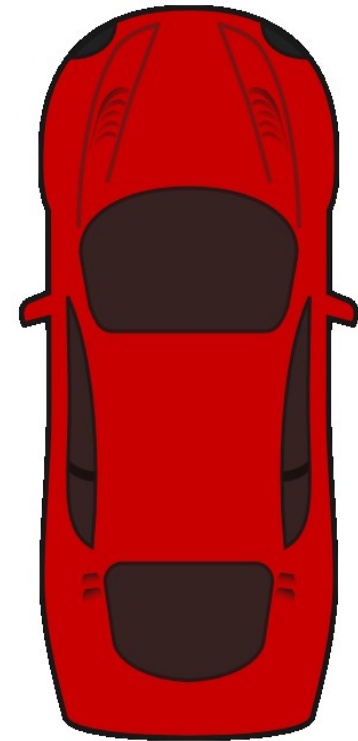

# Frontal Object Avoidance

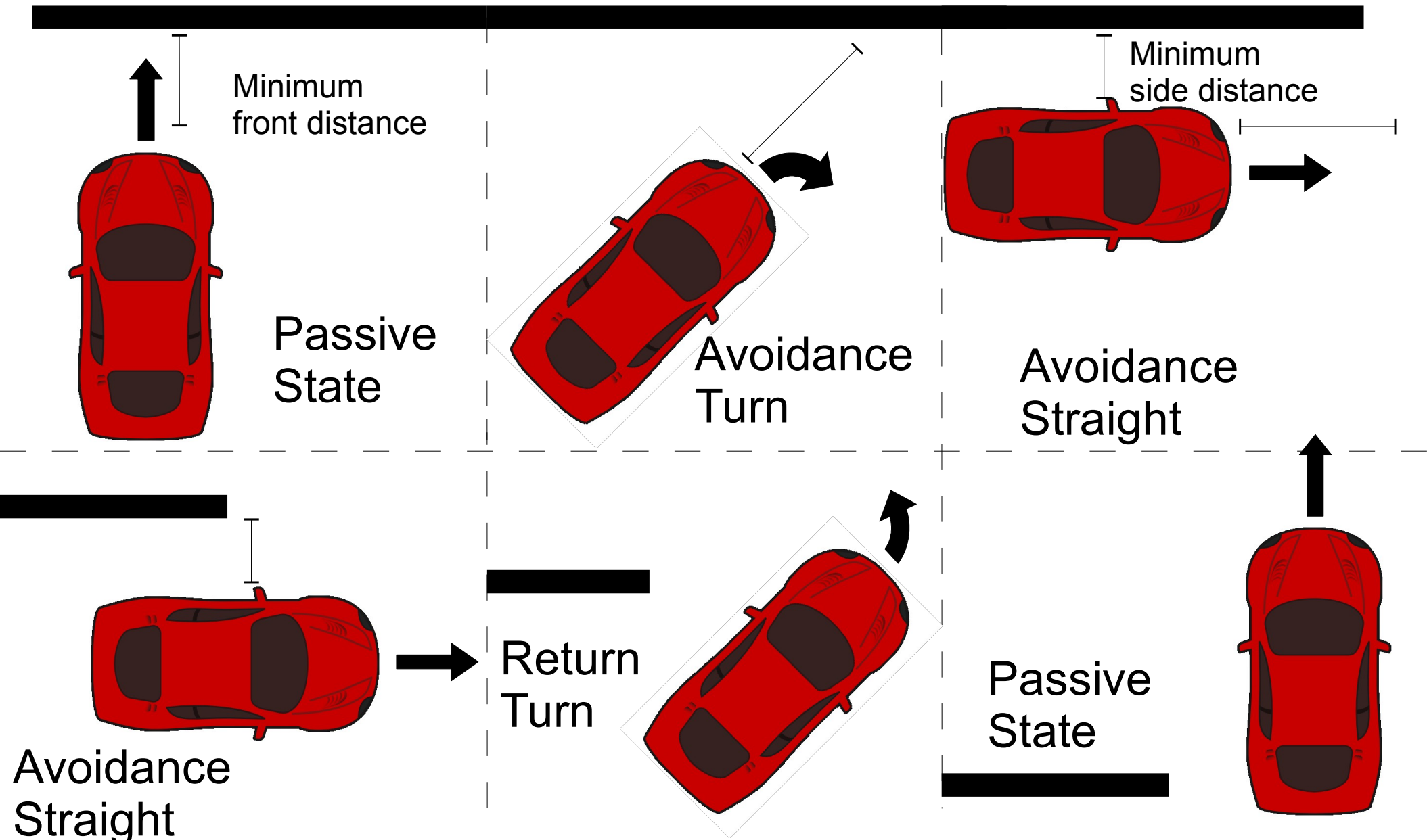

# Dynamic Avoidance

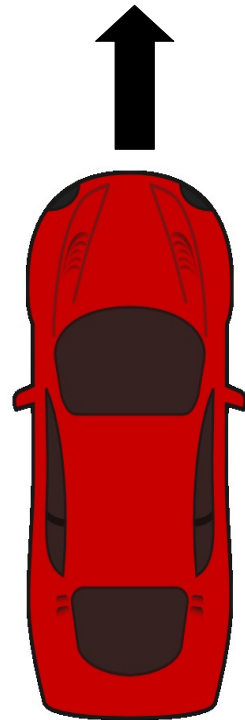

Side Avoidance

<http://www.designedtoat.com/sports3.shtml>

Front and Rear Avoidance

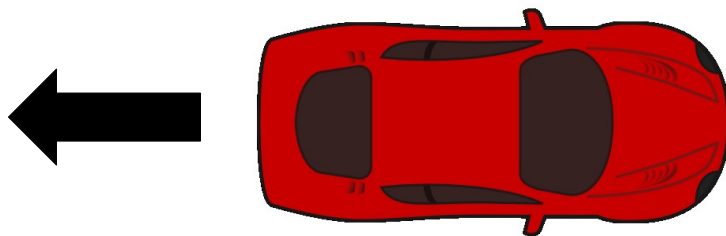

<http://www.clker.com/clipart-26981.html>

Anderson and Kononov

# Parallel Parking

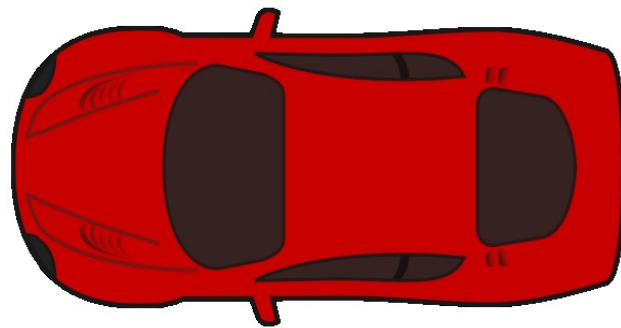
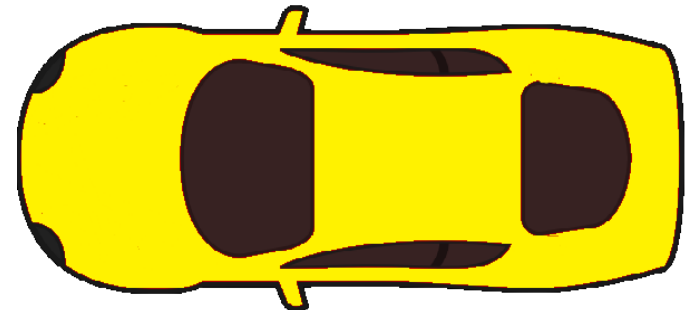
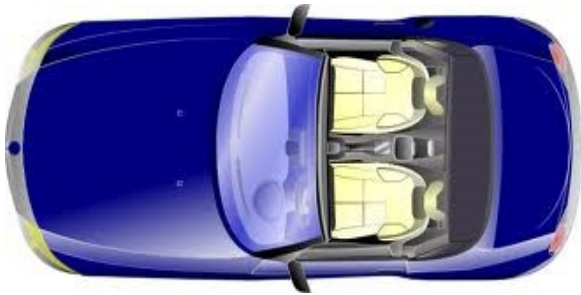
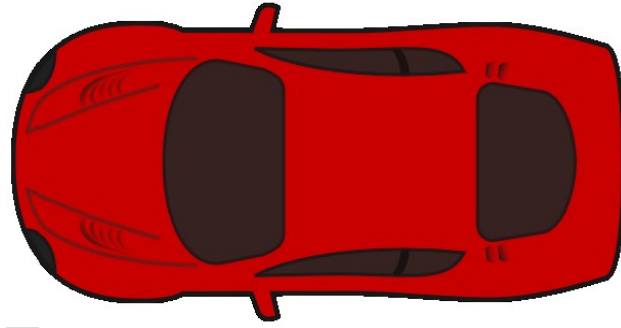
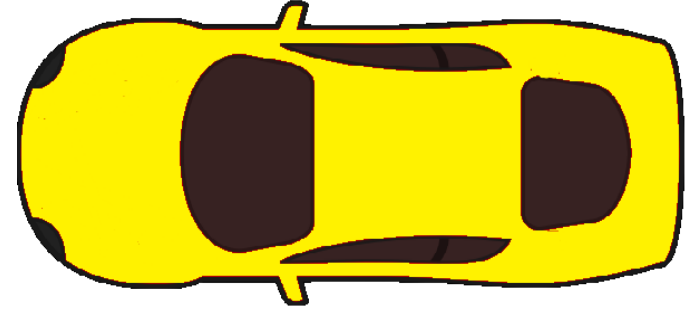
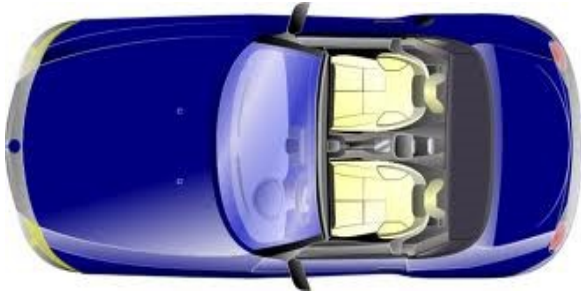

# Schedule

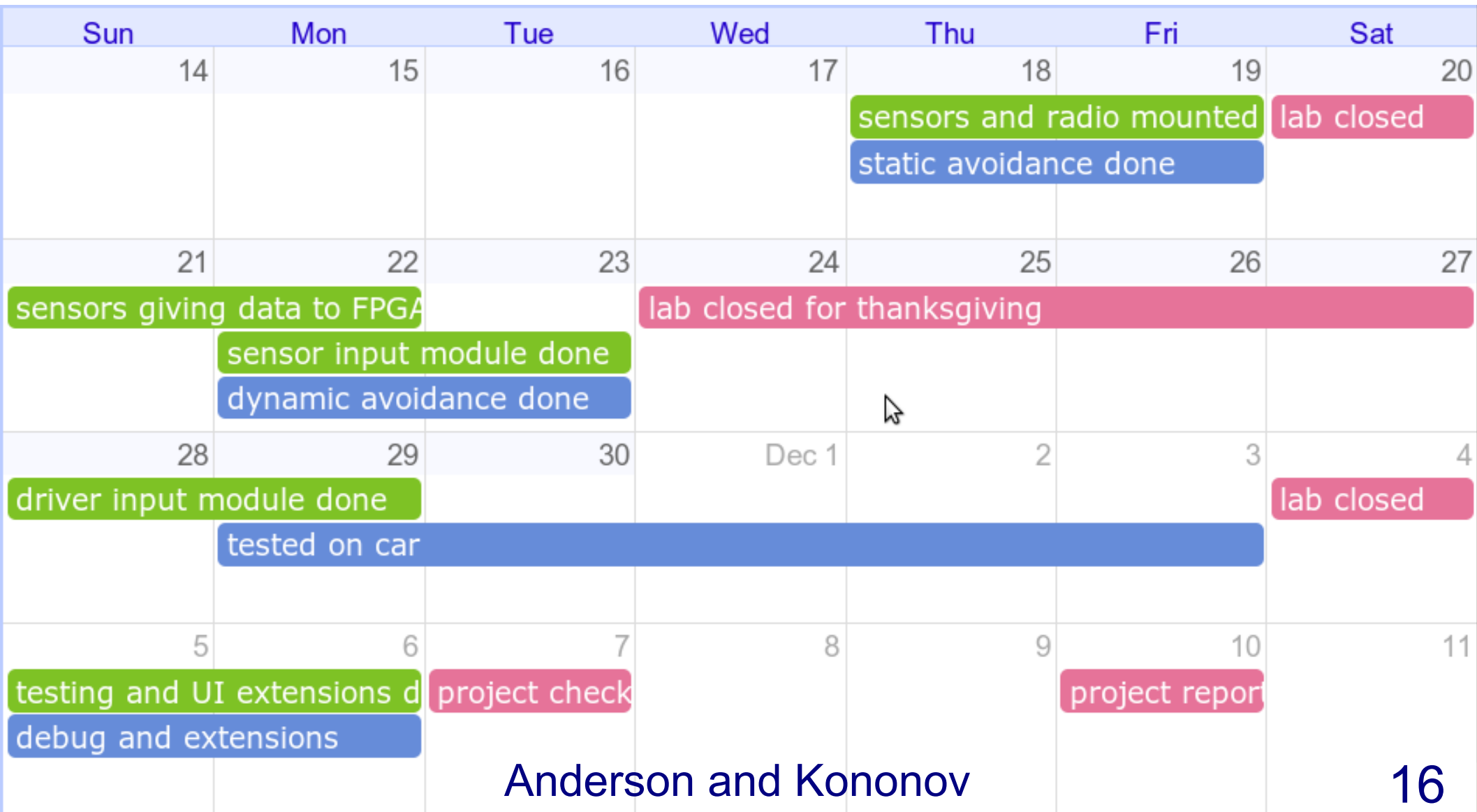
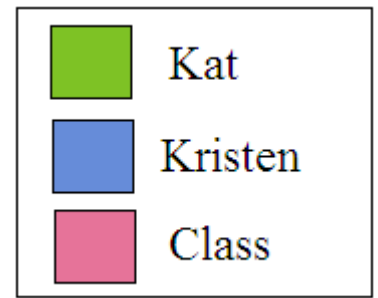



# Conclusion

- Scalable crash avoidance system
  - Distance sensors in all directions
  - Processes all commands sent to the car
- Semi-autonomous features
  - Parallel parking
- Mapping possibilities

**Questions?**