

# Voice Recognition in Hardware

As an Input Device

Tao Ben Schardl  
Nicholas Harrington

# A Functional Overview

- Small sections of incoming audio ( $\approx 20ms$ ) are analyzed and converted into vectors that parameterize the incoming audio.
- Each word is composed of a list of these vectors. Endpoints for possible words are determined by the overall energy of incoming audio.
- Words trained into the hardware are compared against incoming audio signals using a dynamic time warping algorithm (DTW).

# Vector Generation

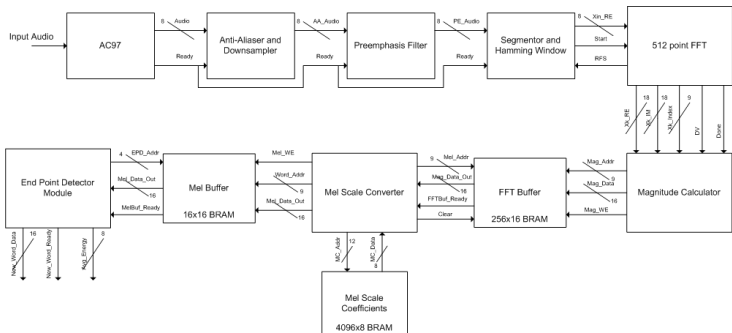

# Vector Generation

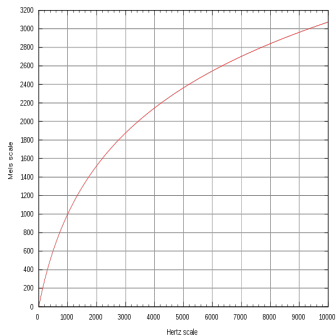

Borrowed from wikipedia

# DTW

## Algorithm

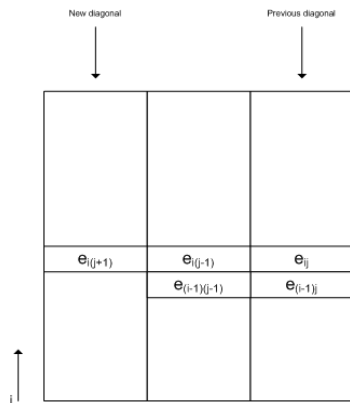

$$e_{i(j+1)} = d_{i(j+1)} + \min(e_{ij}, e_{i(j-1)}, e_{(i-1)(j-1)})$$
$$d_{ij} = d(w_i, s_{j-i})$$

# DTW

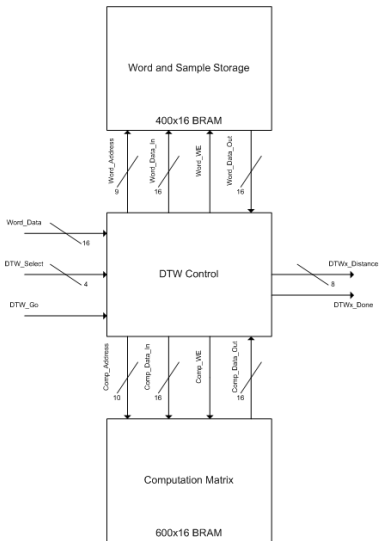

# DTW Control

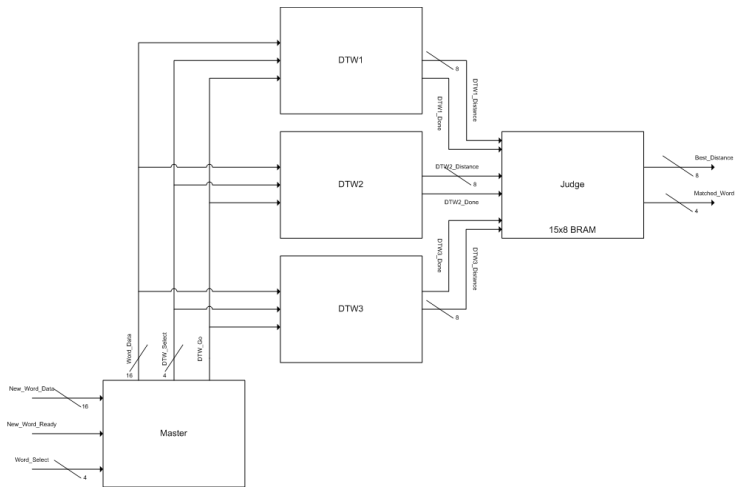

# Mock Layout

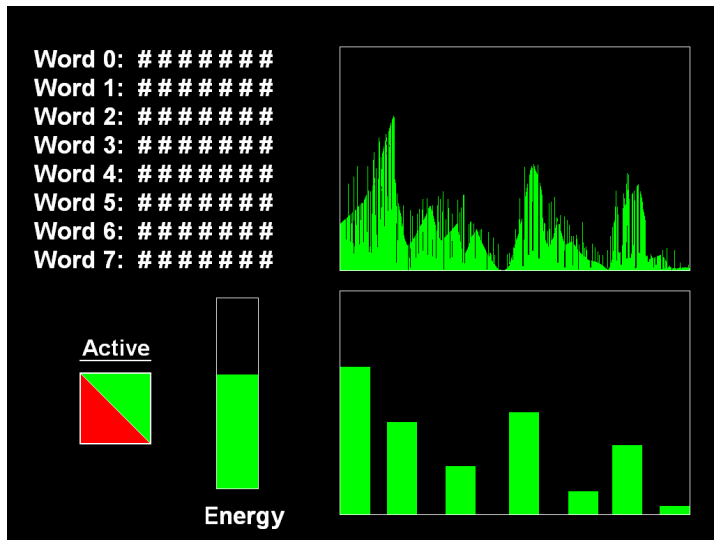



# Output Module

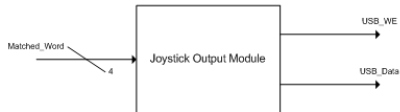
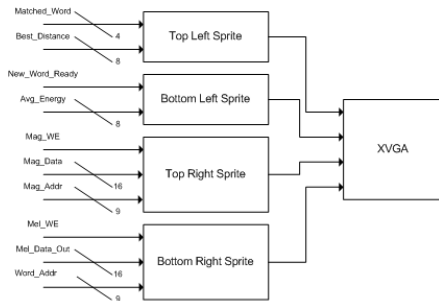

# Timeline

November 2008						
Sunday	Monday	Tuesday	Wednesday	Thursday	Friday	Saturday
9	10	11 Veteran's Day	12	13	14	15
16	17	18	19	20	21 Working FFT	22
23 Working DTW	24 Mel Scale Values	25	26 Finalized Dist. Func	27 Thanksgiving 	28	29 Output Modules
30	December 2008					
	1 <b>P</b>	2 <b>A</b>	3 <b>N</b>	4 <b>I</b>	5 <b>C</b>	6 Working System
7	8	9	10	11	12	13

<http://homeschooling.about.com>

Thank You For Your Time